

Hotel Catalina NMEA 2000 network diagram

My NMEA 2000 network is still pretty small, but I think it's the good time to start to document it.

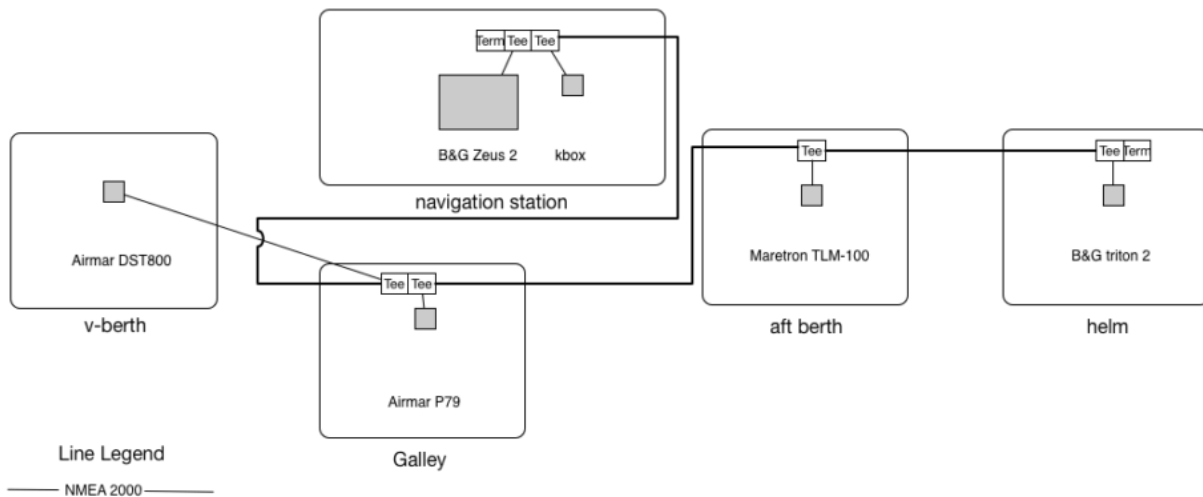

Right now we have:

- Airmar DST800: through hull depth, speed and water temperature information
- Airmar P79: in-hull depth information
- B&G Zeus 2: MFD at the navigation table
- KBOX: wifi gateway and more
- Maretron TLM 100: monitoring main water tank consumption
- B&G Triton 2: main info from the network at the helm

I already ordered my AIS transceiver, so I guess it will be the next equipment I will have to add to this diagram.

Few more items I see adding in the future:

- LCJ CV7 wind instruments (looks to complicated for now, would love to have it, but doesn't see to justify to get the mast down to add it right now – 2019 plan?)
- Actisense EMU-01 or NoLand RS11 engine monitoring, only

a gadget, but gadgets are so fun ☐